

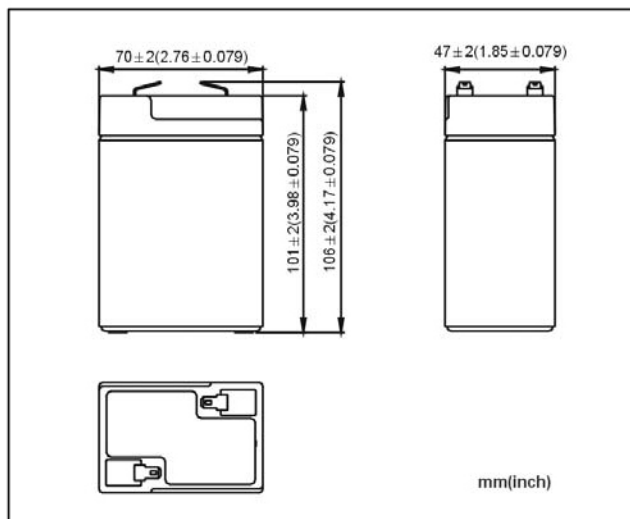

### ■ DIMENSIONS



### ■ FEATURES

- Designed life for floating charge is 3~5 years (20°C);
- AGM valve regulated sealing technology;
- High strength ABS material for container & lid;
- Wide temperature scope of application (-15~45°C);
- Best temperature of application (20±5°C);
- No leaking, safe and reliable;
- Standing or lying down for using, convenient to transport and install;
- High sealed reaction efficiency, little loss of water, no need to add distilled water or electrolyte, simple to use and maintain;
- Low self-discharge rate.

### ■ TERMINALS

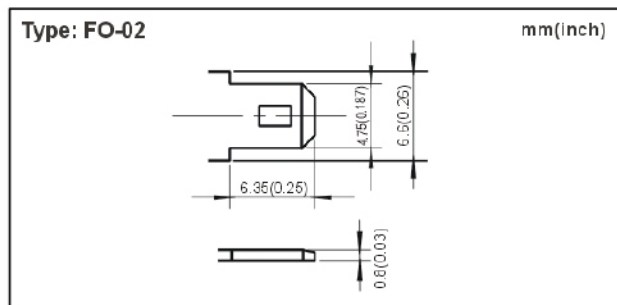

### ■ SPECIFICATIONS

Nominal Voltage	6V	Capacity	C <sub>20</sub>	4.5Ah (5.25V, at 25°C)
Nominal Capacity (C <sub>20</sub> )	4.5Ah (5.25V, at 25°C)		C <sub>10</sub>	4.05Ah (5.25V, at 25°C)
Dimension	Length 70mm		C <sub>3</sub>	3.375Ah (5.25V, at 25°C)
	Width 47mm		C <sub>1</sub>	2.7Ah (5.1V, at 25°C)
	Height 101mm	Internal Resistance	Approx. 20 mΩ (25°C)	
	Total Height 106mm	Max Short-duration Discharge Current	135A(25°C)	
Weight	Approx. 0.80kg	Terminals	FO-02	

### ■ CHARGE

Using Mode	Charging Voltage	Temperature Compensation	Max Charging Current
Standby Use	2.275±0.025V/cell (25°C)	-3.3mV/°C/cell	1.35A
Cyclic Use	2.45±0.05V/cell (25°C)	-5mV/°C/cell	

### ■ STORAGE

- Batteries should be stored in dry and clean warehouse which has good air exchange system. Batteries should avoid direct sunlight. Batteries should not be near to heat (such as radiator, the distance should more than 1m). Batteries should avoid any toxic gas and organic solvent.
- When the ambient temperature is less than 25°C, the longest storage life is 6 months. If ambient temperature is higher, the longest storage life varies as specified in below chart.

Storage Temperature (°C)	≤25	26~33	34~40
Storage Time (Month)	6	3	1

- Batteries should be recharged within the storage life or before using.

Charging methods: maximum charging current 1.35A, constant voltage 2.45±0.05V/cell (25°C);

Charging time: 15~20h; Temperature compensation coefficient: -5mV/°C/cell.

